

The Local

A PUBLICATION OF THE MID-EASTERN REGION OF THE NMRA

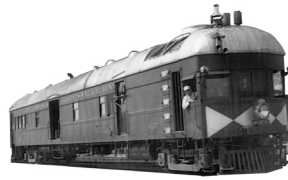

Volume 71

January - February 2016

Number 1

Boy Scouts and the MER

November was Model Railroad Month. One of the significant activities in the MER is our interaction with the Boy Scouts. Several Scout Troops were invited to the Philadelphia Division November meeting. This year your editor received several messages referencing these activities and I am printing them here.

An email from Jeff Shockley:

I just wanted to let you know that as of Tues., Oct 6, there are 10 scouts registered for the Merit Badge class. There are 20 boxcar kits at the club (*First State Model Railroad Club in Dover Delaware, ed.*) and Don Jennings has said that he will be bringing some with him from Cary, NC.

For those members that don't know, this will be the club's 23rd class since we started the Merit Badge project in 2003 and we have awarded 324 merit badges in total. The club has also been recognized by the Mid Eastern Division of the NMRA and the Two Bays District of the Delmarva Council of BSA for our time and efforts in giving these classes. As far as I have researched it, 1,086 Railroading merit badges have been awarded by BSA since 2003. That means that almost 30% of those have come from this club.

If you can, I encourage you to attend the class even if you can't stay the whole day.

An email from Don Jennings:

I would like news of the activities of the First State Model RR Club (above) to go out to everyone in THE LOCAL's area to see if anyone is doing or planning a merit badge class with Boy Scouts. HO Scale car kits are available and can be sent to the club having a merit badge class. I need to know where, when, and how many are needed in a timely manner.

Our Divisions have a lot of members knowledgeable of railroading. It would be easy for them to do a merit badge class or ask for help from me. If First State club can do it then a lot of other clubs could also try.

A good side effect of the merit badge class presentations is for ever Boy Scout there are usually two

parents. Those parents could be joining the division and /or railroad club after seeing their son at a Railroading Merit Badge class.

I am still hoping that more divisions will get involved with the Boy Scout's Railroading Merit Badge program. My email for any questions people may have is donj1044@aol.com

Here is how one young boy is celebrating Model Railroading Month



Alexander Avni of Virginia made this display for the Dolley Madison Library in McLean, Virginia. Alexander's exhibit will be seen by the patrons of this branch the Fairfax County Public Library all through November 2015. Alexander, five and one-half years old, is a member of the MER.

For More Information Contact:
Kate Avni (his mom) 571 533-9610

The Local

Official Publication of the Mid-Eastern Region, NMRA - A Tax-Exempt Organization

The Local is published six times a year. Opinions expressed here do not necessarily reflect those of MER elected officials. Commercial suppliers, supplies and materials addressed in The Local in no way constitute an endorsement by the MER. Copyright material that appears in The Local is used for educational and historical benefit only and does not constitute infringement of the copyright holder.

EDITORIAL STAFF



Editor / Publisher
Earl Hackett
3 Forrest Lane
Hockessin, DE 19707
(302) 239-5509
hacketet@verizon.net

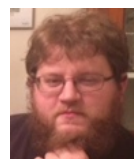

Webmaster:
James Brechbiel
frodo@mer-nmra.com

<http://mer-nmra.com>

ADMINISTRATIVE STAFF



President:
P. J. Mattson, MMR
129 East Avenue
Swedesboro, NJ 08085
(856) 467-0421
pjmattson@comcast.net



**Director and
MER Contest Chair:**
Martin Brechbiel
3404 Monarch Lane
Annandale, VA 22003
(703) 309-3082
martinwb@verizon.net



Achievement Program Mgr
Charles Flichman, MMR
6909 Crandall Court
Clemmons, NC 27012-9056
(336) 766-8353,
cwfligh@aol.com



Vice President
Chuck Hladik
198 Fire Oak Lane
Rustburg, VA 24588-4149
(434) 941-7456
VP14@mer-nmra.com

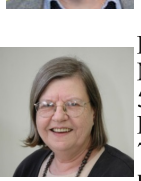

Director:
Michele Chance
5884 Circlewood Dr
Kannapolis, NC 28081
704-933-4200
michelejc@carolina.rr.com



Nominations Chairman:
Bob Minnis, MMR
11 Marwood Drive
Palmyra, VA 22963
(434) 589-3011
kahlualab@aol.com



Secretary:
Ken Nesper
1218 Kearney Street, NE
Washington, DC 20017
(202) 269-3890
oscaledc@yahoo.com

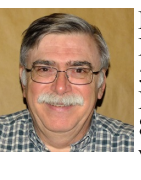

Director:
Ken Montero
524 Lancy Drive
Midlothian, VA 23114
804-794-5704
va661midlo@comcast.net



Archivist: Chris Conaway
407 Kings Highway
Moorestown, NJ 08057
(856) 439-1742
chrisconaway@aol.com



Treasurer:
Thomas R. Buckingham
7216 S. Osborne Road
Upper Marlboro, MD 20772
(301) 952-0427
tombuckingham@juno.com

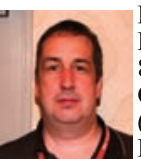

Business Manager:
Bob Price
801 S. Newton Lake Dr.
Collingswood, NJ 08108
(856) 854-8585
Business@MER-NMRA.com



Registrar: Bill Grosse
24 Bethel Avenue
Hamilton, NJ 08620-2306
609-585-4616
MER-Registrar@mer-nmra.com

MER Division Superintendents



New Jersey Division 1
Robert Clegg
(856) 696-0463
bobcatcs@comcast.net
www.njdivnmra.org



James River Division 5
Phillip R. Taylor
(434) 589-6006
drphilster@gmail.com
<http://www.trainweb.org/jrd/>



Carolina Southern Division 12
Jack Haynes
7317 Easen Ct
Charlotte, NC 28211-6183
superintendent@carolinasouthern.org
www.carolinasouthern.org



Potomac Division 2
Brian Sheron, MMR
(301) 349-5754
BWSheron@mac.com
home.comcast.net/
~potomac_nmra



South Mountain Division 10
Paul Rausch
(717) 401-0747
rausch6976@comcast.net
www.smdnmra.org

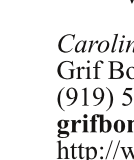

Carolina Piedmont Division 13
Grif Bond
(919) 556-7066,
grifbond@embarqmail.com
<http://www.trainweb.org/cpd13>



Philadelphia Division 3
Joe Bergmaier
jober922@gmail.com
<http://www.phillynmra.org/>



Susquehanna Division 11
Barry Schmitt
(717) 877-1810
bschmitt@susquehannanmra.org
www.susquehannanmra.org

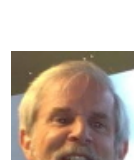

Chesapeake Division 14
Tom Casey
(410) 426-8947
super.chesdivmernmra@gmail.com
www.chesapeake-nmra.org



Tidewater Division 4
Gary Brown
(757) 481-2348
alleghenyrr@yahoo.com
www.nmra-mer-tidewater.org

From The Business Car

By P. J. Mattson, MMR, MER President

Here we are at another year, 2016. I hope you had very happy holidays. With the onset of Winter and bad weather outside, it is time to do some serious modeling. Think about going for some of the Achievement Certificates. You should be recognized for your outstanding work. The date for the next board meeting has not been set; it may be held in April. The January Budget meeting was held Thursday Oct. 22nd 2015, at the convention. The Budget for the year 2016 was presented and passed. With the holidays, there has not been any new business presented. This year the positions

for MER Officers are up for election. There are four positions. These positions are President, Vice President, Secretary, and Treasurer. I'd like to see a few of you run for these positions. If you would like to run for any of these positions please contact

Bob Minnis (kahlualab@aol.com)

Bruce Barrett (greenjeeps2@yahoo.com) or

John Janosko (johnajan@embarqmail.com)

Prepare a statement (250 words for ballot – 500 words for webpage resume and a good headshot picture). Until next time stay on the right track.

Keeping in Touch...

By Bob Price, MER Business Manager

A Happy New Year to all our MER members and Local subscribers. The new year is a good time to remind everyone that those members receiving the electronic version of the MER Local (eLocal) do not have to pay the annual subscription rate. If you are receiving the paper version of The Local and want to save \$9, consider switching to the electronic version. If you have a computer with a printer, you can always print your own copy. As a bonus, many of the 2015 issues of the eLocal had additional pages that were not available in the printed version of the MER Local.

Also a reminder that if you have a change of either your home or email address, please be sure you notify either National or the MER Business Manager of the change. If you are receiving the paper MER Local and requested that the Post Office holds your mail while you are away, please let us know. The Post Office returns Locals for postal patrons that are "temp away". The MER pays for returned paper copies of the MER Local and election ballots, so it is an added cost to the MER.

Finally, a reminder that the MER has been using MailChimp to send it bulk email message blasts. These messages include availability notices for the eLocal, MER Convention updates and any other communications as approved by the MER Board of Directors. MER emails are only sent to communicate and share information. This is something that many in the membership feel is missing. Yes, there are some members who do not want the emails. For those members, the MailChimp service provides you with an option to un-subscribe. If you do not want to receive these emails just click on the un-subscribe link on the email. You will be removed immediately from future email blasts. If you are not receiving emails from the MER and would like to, just send your name and email address to the MER Business Manager (see page 2).

As always Keep in Touch with any questions or changes in your subscriptions or addresses. A current address on file saves the MER some money.

From the Editor

Earl T. Hackett, Jr.

There are a couple of different items in this issue. The first is an article covering the basics of constructing a resin kit. These techniques are quite different than those used for the common injection molded plastic kits. It is well worth reading and may inspire some readers to try one of these kits.

The second article is an electronic device used to count the number of moves and keep track of time on a

switching puzzle layout. This one is designed for DC operation. For DCC operation the circuit design would be similar, but the software would be very different. I taught myself the basics of digital circuit design. It is actually quite simple and has come in handy for designing return loops, signaling, switch machine operation, and other electronic functions needed on my layout. If there is sufficient interest I may start a column at the end of the electronic version covering these topics.

Photographing Layouts

Earl T. Hackett, Jr.

Visits to layouts are a major draw for conventions. Photos of layouts for publication in *The Local* are a good way to advertize the convention while at the same time they can be inspiring to modelers who, for whatever reason, can not attend. With that in mind, in this article I'll go over the equipment you need and techniques I've found to work well.

The most important thing in photography is lighting. Lighting for photography is probably the last thing a model railroader thinks about while building his layout, so bring lights. Do not use a flash - the foreground will be overexposed and the background under exposed. There's no need for fancy studio lights, simple clip-on aluminum reflectors work just fine. You can still purchase photoflood incandescent bulbs, but they only last a few hours and I don't know how well they work with digital photography. I find a 75 watt (minimum) equivalent 5000°K "Full Spectrum" compact fluorescent bulb (CFL) with a Color Rendition Index (CRI) over 80 works just fine. An inexpensive bulb that meets these requirements is the TCP 801019-50 available at www.1000bulbs.com for \$2.25. I buy them by the 12 bulb case. I use them throughout our home. CFLs last for years. Last month I replaced one originally installed in 2006 because, although it was working just fine, we didn't like the color of the light. Don't forget a couple of extension cords and something to clamp the bulbs to such as a 6 ft long 1 x 4 attached to a plywood base. Bring at least 3 lamps so you can provide uniform lighting and eliminate shadows.

The next most important item is a good digital camera. It doesn't have to be expensive, but you should be able to control the aperture and preferably have the ability to focus manually. My old Canon 20D is overkill for this application, but it has all the features I need. For the greatest depth of field, you want to shoot at the smallest aperture available on the lens, preferably f16 or smaller - a higher value f stop. Even with bright lighting this will require a long exposure so a tripod is a must. If available, use a 2 second shutter delay and if using an SLR model, lockup the mirror prior to making the exposure. Using these features reduces camera movement during exposure, producing a much sharper image. You can take hand held photos, but it is difficult

to get a sharp image, especially in a dark basement.

In many cases the small aperture will provide sufficient depth of focus. If you have any doubt about the focus take 10 or 12 photos with the camera manually focused at various depths. I can combine the in-focus portions of select images into a single image, providing excellent depth of focus. This requires that neither the camera nor anything in the scene moves between shots. If you wish, you can do this yourself with CombineZP.

Here's something I learned last summer. Bring along a piece of light blue matte board, the cardboard used for matting framed photographs. It's readily available at craft stores in 32" x 40" pieces. You may not need it often, but when you do it is a real life saver. This will serve as a backdrop when none is present. A workbench in the background is a big distraction in a photo of a well done model.

Finely, a comment on composition. Double check to insure that there are no foreign objects in the scene. I've made that mistake more than once. You don't notice until you see the print and there's a 1:1 pencil sitting right in the middle of the track. Those things are difficult to remove even with the best digital editing software. For the best perspective, take the photo from as low an angle as possible to simulate what a scale size person might see.

The grain elevator on Chris Conaway's layout illustrates some of these problems. Here is a beautifully executed model of a grain elevator that I wanted to showcase, but as Chris pointed out, living in a 100+ year old house has significant disadvantages. The lighting is terrible. At 6' 4", when I stood up my head was between the rafters so any kind of normal lighting was out. Chris did the best he could with rope lights and other lighting that could be stuck up between the rafters, but for photography it was just not going to work. The cheap clip-on aluminum reflectors provided full spectrum lighting for good color reproduction and put some nice highlights on the silver elevators.



Grain elevator as photographed



Effect of background on image detail

Finally for publication I cropped it a bit and put in one of my backdrop photos, but I couldn't recover the stay detail very well. The image is what was published. It is OK, but it could have been a lot better.

If there is any concern about depth of focus, below is an example, taken on Rick Bicomore's layout, of improving depth of focus sby combining multiple images.



Near



Mid Range



Far

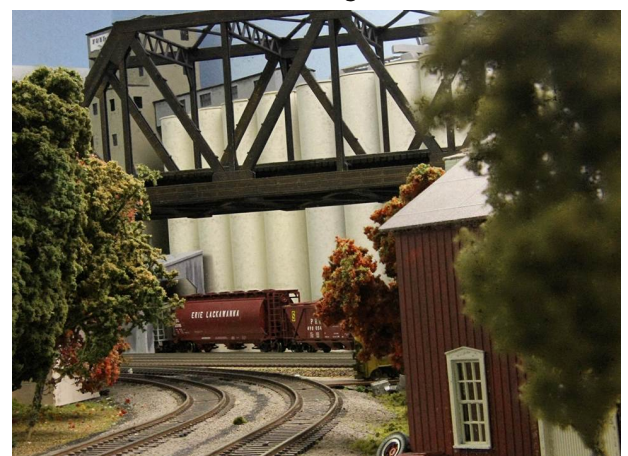

Combined and cropped

The Contest Room and Special Awards -- 2016

Martin Brechbiel, MER General Contest Chairman

The calendar has rolled around again and it is time for you all bring your models to Tracks to the Triangle – the MER 2016 convention in Durham, NC (October 20 - 23, 2016) and to enter it into any one of the contest categories! Beyond the regular Contest categories, there are several Special Awards that you should consider bringing that “Special” model to place into consideration. All of the information pertaining to the Special Awards, criteria, qualifications, Judging, etc. are available on the MER web site, <http://mer-nmra.com/Achievement.html> and on our Yahoo Group, The MERMailbag at <https://groups.yahoo.com/neo/groups/MERMailbag/files/The%20Special%20Awards/>

Just click on the name of the Award to be linked to the pdf files for that award’s information! All of the forms that you need are available on the MER web site at <http://mer-nmra.com/Achievement.html> . Downloading and filling these out well in advance is worth your time & effort since you can type right into the form. If you need or can not locate the forms, contact me directly (director3@mer-nmra.com).

We saw an outstanding selection of very high quality models in Mt. Laurel in 2015 that resulted in an excellent percentage of Merit Awards being issued, 57%! I have every hope and expectation that the MER will continue to meet that level of achievement since the MER has a high number of truly outstanding modelers. We will also

need the continued great service of our existing cadre of experienced Judges as well as our Apprentice Judges. In that same light, I’d like to hear from members of last year’s judging crew to confirm (at least tentatively...) who will be coming to Durham when they have a chance. And as always, I want to hear from any modelers that would like to become Judges.

Lastly, participating as a Judge is a great way to learn and improve your modeling skills as well as gaining a “hands-on” practical understanding of how the judging matrices are applied. On top of that, judging is another activity that counts towards your Association Volunteer category in the AP program! And, having now mentioned the AP program, I’d like to invite any and all of the Divisional AP coordinators to drop by the contest room, take a look at the entries, and even participate in the judging session! Come to Durham and bring your models to the Contest Room!

In addition to the Judged Contest, we also have a popular vote Photo Contest with multiple categories. Lastly we also will have an array of Special Awards that include the “Favorite Train” and “Favorite Model” popular vote categories. These Special Awards and awards for all of the categories in the Model and Photo contests will be presented at the convention banquet on Saturday evening. Awards and other contest information will soon be available on the convention website!

THE BEST OF SHOW AWARD is given to the model that scores the highest point total in the judged model contest. Not only is a plaque awarded but this includes registration to next year’s MER convention.

THE PRESIDENT’S AWARD for 2016 has been chosen by MER President Mattson and will be given for his favorite Diesel locomotive.

THE CLYDE GERALD AWARD is sponsored by the MER and named for the late Clyde Gerald, former MER Business Manager and long-time modeler. It is awarded to the kit-bashed model which scores highest in the judged model contest. Be sure to check the definition of kit-bashed for this award!

THE BLUE LANTERN AWARD is privately sponsored and chosen by long time MER modeler Terry Nesbit and his Narrow Gauge Car Shop. The Blue Lantern is given to a model best representing branch or private line equipment or facilities, which contain no more than forty (40) percent commercial parts. The prize—a genuine railroad lantern—is presented to the winner by Mr. Nesbit.

THE PHILADELPHIA DIVISION MODELER AWARD rewards excellence in model building by first time entrants in an NMRA sponsored judged model contest. The highest score achieved by a new modeler in the contest is worth not only a plaque, but a cash prize of twenty-five dollars!

THE PRIDE OF DIXIE AWARD, sponsored by the James River Division, will be awarded for a backwoods/portable sawmill this year.

THE RAY BILODEAU NARROW GAUGE AWARD is also privately sponsored by a group of narrow gauge modelers, and encourages building models depicting aspects of narrow gauge railroading. The narrow gauge model that scores highest in the model contest is presented a plaque.

THE GREAT DECALS! AWARD is an award for an excellent model that includes a Great Decals! product in its construction and/or finishing achieving the highest judged score in lettering & finish for a model that employs a product demonstrated to be from Great Decals! that also receives a Merit Award.

THE FAVORITE TRAIN AWARD is a popular vote award and will be included on the Popular Vote ballot. Yes, members who can find their way to the contest room and fill out a ballot get to choose the winner!

In my continuing role as MER General Contest Chairman, I'd like to encourage everyone to consider bringing a model to enter into the various NMRA contest categories. I've found it to be very educational and of considerable general value. My modeling skills continue to improve from participating in the AP program and

Contest room. I feel this to be a valuable part of the MER and the NMRA, and I also know that the MER has a great number of truly outstanding modelers out there. So, bring your models to the contest room this Fall in Durham, NC. If you have any questions, contact me: director3@mer-nmra.com

Delaware Valley Turn Wrap Up

Bob Clegg, Chairman

The 2015 MER Fall Convention was by all accounts a terrific success. Held over the weekend of October 22 to 25, the weather cooperated and members came in large numbers. The final registration was 279 members, and with families included, 327 total attendees. About 2/3 were from the MER and the other third from other regions, primarily the NER.

The NER heavily supported our convention this year since they had not planned for one of their own. The Philadelphia Division was also in much evidence. The folks from across the river contributed heavily to the clinics and home railroads on the tour. The New Jersey Division is grateful for their assistance!

The only "complaint" heard was that there was too much to do and see and it was impossible to do and see it all. Well... guilty, but by design! We had 51 hours of clinics, none of which were repeats. We also had a total of 57 home and club railroads to visit, and 140 slots for operating sessions, of which 107 were used, on about a dozen different railroads. There were also prototype tours to Amtrak, Conrail, and Patco.

Something we've not done at an MER convention before, a sizable Free-mo railroad was set up right in the convention hotel. Modules from New England, Maryland, Virginia and from members of the New Jersey Division were connected to create a railroad about 100 feet from end to end. There were even several operating sessions held on the modules so folks could try their hand at operating without leaving the hotel. Thanks go to Mike McNamara for arranging the Free-mo display

and to the module owners for bringing them!

The Silent Auction also proved to be very popular...actually too popular. There were 969 items entered in the auction, and the total of the sales was in the neighborhood of \$10,000. In spite of the size, it went fairly smoothly and everyone went home with their purchases, their cash, and/or their unsold items.

As you all know, these annual conventions are for the members to come, see, learn, and get together with friends, old and new, and this convention was no exception. In addition, although it is far from the primary purpose, the convention earned about \$6000 that will be split between the region and the host division. That's a good thing, as it enables us to continue to have quality conventions in the future.

Speaking of the future, the next MER Fall Convention, Tracks to the Triangle, will be held in Durham, NC the weekend of October 20 to 23, 2016 at the Marriott Research Triangle Park. This promises to be another great MER Fall Convention. Check it out at the website: <http://www.mer2016.org/>

In closing, there are some folks who need to be thanked for their contributions. Thanks to all of our clinicians, open house hosts, and operation session hosts. Thanks also go to the DVT committee and the Region's support folks, Eric Dervinis, ECC and Bill Grosse, Jr., your registrar. And last but FAR from least, to Fred Willis, the Clinics coordinator and Chuck Higdon, Home Tour and Operating Session coordinator. All of these folks deserve a long round of applause for their work!

How to Build a Resin Kit

Amesville Shops

I am often asked, "How is building a resin kit different from a regular styrene kit?", and "Can you tell me how to build a resin kit?" It seems to be feared; a mystical and arcane process for most model railroaders. Well, it isn't as easy as falling off a log, but if you are willing to try a few new things and invest in a few simple tools (some of which you may already have) then you can learn to build resin cast models.

Styrene and resin models are made by very different processes. A styrene kit is mass-produced in lots of tens of thousands. Engineers and machinists spend many hours to develop a highly-engineered model and cut the molds for it from steel or aluminum. It is a high-speed process where heated styrene plastic is injected into those molds under high pressure over and over again. The tooling is expensive, but because of the speed and volume of production the cost of the model is reasonable. A resin craftsman kit, on the other hand, usually comes from a garage based business. Simple RTV rubber molds are made from hand-crafted parts. A two-part resin, usually polyurethane (PU), but sometimes epoxy, is mixed and poured into the molds. Once these resin harden they can not be heated and reformed like styrene and are termed thermoset resins. Often only a few sets of parts can be made in a day, maybe 15 or 20 full kits on a good day and production runs of only 250-500 kits.

The big professional company can make the same model available to nearly everyone who wants one, but it has to have wide appeal or the economics don't work. A resin kit producer serves the smaller niche market where the big boys can't go. They can offer the special, the unusual, the limited interest models the big guys can't afford to touch. So now we know why the kits are different. Let's talk about how to build a resin kit.

Resin kits are a little different from the styrene kits you are probably used to. For one thing, thermoset resins can't be bonded with solvent glues such as Tenax or MEK. The preferred glues for working with PU resin are cyanoacrylate (CA) and epoxy. Epoxy is super strong, but it takes time for the bond to set up; anywhere from 5 minutes to 24 hours depending on the type you buy. CA on the other hand sets up in seconds, faster if you use a 'kicker' that sets it instantly. But CA doesn't have much shear strength (parts can pop off if stressed from the side), and can fail completely if exposed to cold conditions. I use both depending on the situation, and try not to leave my models in the trunk of the car during winter months. :)

You also need to be really careful about keeping your fingers away from the joint area while the glue is active

or you'll quickly find the model glued to your fingers. Don't panic, acetone (nail polish remover) will free you quickly, but you may want to wear safety glasses when working with this stuff, as gluing your finger to your eyelid is much more delicate operation to handle. Not to mention the fumes are quite strong and irritating to the eyes at times – which is what leads to touching your eyelids when you shouldn't.

If you use CA to assemble your resin models you can take advantage of one interesting chemical feature - Acetone doesn't bother PU resin, but it is a solvent for CA. If you make a mistake you can brush acetone onto the joint and it will dissolve the CA glue, letting you take the joint apart and try again. Try that with styrene! You can also use acetone and a Q-tip to scrub the glue residue off the model after you get your finger unglued from it.

So what's in the box?

What you will usually find is a bunch of flat parts that may have a lot of flash, extra parts for details made from resin, styrene, pewter or brass, wire, a sheet or two of instructions, and possibly decals. Some kits may include one-piece body castings, which are much simpler to build. It's quite intimidating on first glance, but you can do this!

First read through the instructions carefully and completely. It's often very important to do things in the prescribed steps. There may also be suggestions of how to do something that may not be obvious and could save you time and heartache later. You'll want to familiarize yourself with all the parts and how they go on the model before you start anything.

After reading the instructions, collect all the parts that are not water-adverse and place them in a bowl with warm soapy water. Out of the box, almost all PU resin parts are coated mold release that keeps the resin from sticking to the mold. You need to wash this off or the glue may not bond the parts together, and painting will be impossible. In some rare cases the parts must also be washed in acetone, it should say in the instructions if this is needed. Clean the parts well (I use a soft toothbrush), rinse in clean water and blot dry with a paper towel.

The next step is to clean up the flash on the parts. **GO SLOWLY AND TAKE YOUR TIME WITH THIS STEP.** I cannot stress this strongly enough. Resin models are made or broken here. Use a combination of tools - hobby knife, sandpaper, files. You will also want to keep your machinist square (Harbor Freight \$8) handy to check for square straightness. A 6" caliper (Harbor Freight \$20) is useful to check critical dimensions. HF also has needle

files and other useful modeling tools for fair prices.

I could do an entire article on how to prepare your castings, but let me throw out a few of the best tips I know:

- Trim the flash off all major parts carefully, using the hobby knife, sandpaper and files where appropriate. Work slowly, a little at a time, being very careful not to take off too much material at once.
- If you have identical parts, like two side walls of a boxcar, constantly compare them to each other as you go. Make sure that corners are square and that sides are straight, but most importantly that the parts are identical in size and shape when placed back to back.
- When trying to keep flat edges straight align the file parallel to the edge, running across the entire length of the edge. When sanding, place the sandpaper on a flat tile or glass surface and move the part on the paper.
- Work carefully around cast-on details being careful not to damage or remove them. You paid up front for that accuracy; it would be a shame to sand it off by accident! Also be wary of sanding off subtle detail like wood grain. Examine parts carefully before sanding or filing them.
- Very small parts are often cast together and appear on the same sheet of parts, kept together by a paper-thin sheet of flash. It may be wise not to remove and clean up these parts until they are actually needed to keep them from getting lost.
- Occasionally there may be an air bubble hole on a part. To fill a hole, mask the surface and trowel in some putty (Nitro-Stan, Squadron) with a toothpick. When it has set up, sand lightly with fine sandpaper until flush, then remove the masking and continue prepping.
- If it is necessary to drill holes in parts it's often a good idea to do that before assembly. You have better control of the parts and don't risk breaking off applied or cast-on details.

Model Assembly

So now you have your parts all ready to go. Follow the instructions and start assembly. Use only a little bit of CA or epoxy, especially where the joint can be seen. You may set a joint with small droplets of CA applied with a pin, then reinforce the joint with epoxy on the inside. Thin CA cement can be touched to the joint, and it will wick into the space between through capillary action. Epoxy is a much thicker glue and must be applied sparingly. Messy joints with glue smeared on the model must be avoided. With either glue the worst thing you

can do is try to smear off the glue with your fingertip. With CA it is best to leave it and let it set up, and then sand it off with fine sandpaper. (Or try the acetone trick, but your joint might come apart too.) You can deal with epoxy the same way, but it can be removed with a solvent (MEK or lacquer thinner) before it sets up.

Special clamps can be purchased to align parts during gluing, but you can make your own with a block of wood and some rubber bands. Take your time setting up the joint so it is clamped in position while the glue sets.

Tools

You will need a pin vise and a small drill index for sizes 61 - 80. Purchase extra 76 and 77 bits to replace the ones you will break.

Good needle nose pliers and a diagonal wire cutter are mandatory. Flush cutting pliers are particularly useful. McMaster Carr (www.mcmaster.com) has industrial grade tools suitable for any modeling task.

Details

Use common sense to decide when to apply certain details. For instance, it is much easier to put in the grab irons on a boxcar before the floor is glued into place. The brake wheel and underframe levers and wires shouldn't be applied until the model is almost done. Trucks and couplers don't go on permanently until after the model has been painted.

Resin kits usually don't have cast-on grab irons, or other fine details. These kits come with a package of separate detail parts you are expected to apply to the car to complete the detailing. If you haven't done it before, first practice on an old styrene car. You may be discouraged by your results the first time. Go into it expecting that. You can learn to do this, and very soon you will do it well.

In many cases the model will come with formed grab irons. You may need to plot out where the holes for the grabs go on the side or end of the car. If so, use a sharp pencil and mark hole locations. Mount a sewing needle (not a pin) in your pin vise. Carefully locate the tip where you want the hole and press it into the resin to form a starter hole to center the drill bit. This will keep the drill bit from skating along on the surface and producing a hole where you don't want it. Some models have divots or depressions already located on the car, I suggest you use the needle anyway - it will work better than not using it.

Set the part on a block of wood so the hole is backed up and doesn't blow out as the drill bit passes through the back. Replace the needle with the appropriate drill bit (usually #77 for grab irons), and set the bit into the needle hole. Place the index finger to hold the pin vise perpendicular, and the thumb and middle finger to rotate the pin vise. You do not need to turn the pin vise in complete revolutions. A back and forth motion of about 1/2 revolution or more is adequate to keep the drill working. Try to apply even pressure with the index finger, avoiding side stresses on the bit (which will break it). You don't need to stop pushing down when the bit is rotating backwards. Work slowly and consistently until the hole is drilled through the part.

When applying grab irons use a spacer of wood or styrene under the rungs to hold the irons a consistent distance from the car side. Set the rungs into the holes, and bend over the back of the wires inside the model to lock it in place. Cement the grabs in place with epoxy - as a part subject to a lot of handling, CA is too delicate for this. (*Modelers should take a look at Welder adhesive available at Amazon. Ed*)

When separating small castings like nut-bolt-washers (NBWs) from their sprues, leave a bit of the stem to locate the part on the model. Drill out holes for NBWs the same way you did for grab irons, but know in advance that handling the tiny parts can be maddening. I often use the point of a very sharp hobby knife blade to poke them gently, which holds them on the tip, where I can maneuver them into place and slip the stems into the holes. I have heard a bit of sticky beeswax on the tip of a toothpick works even better.

Apply any other detail parts as well, using CA or epoxy where appropriate. Use cement sparingly. Refer back to the instructions often to ensure you understand how to apply the parts and in what orientation. Go slowly. Allow the previous cemented-on parts enough time to set firmly before applying other details.

Finishing

Resin kits almost never come painted. After construction of the model is completed, wash it to remove any fingerprints, oil bloom from the resin, beeswax, or pencil marks. Don't immerse enclosed cars in water, but a soapy scrub and rinse probably won't trap much water inside. Blot dry with a paper towel and let the model dry out thoroughly.

Select an automotive primer to coat the model with. Auto primer is designed to stick well to plastics, has a very fine pigment, it dries very fast, and it provides a

good surface for subsequent color coats of almost any kind of paint. I have heard excellent reviews of Wal-Mart's \$1 aerosol primers. Primers are available in four colors; white, red, black and gray. Select the appropriate primer color based on the final color coat. Test its compatibility with your color top coat on a piece of scrap before applying it to the model. Apply a couple of very light coats of paint rather than one thick coat, waiting about 15-20 minutes between each coat. Stop when there is no exposed resin. Let the primer dry thoroughly, 4-12 hours. Consult the can for better information about drying time.

From here you can paint the model with any type of paint you wish, with brushes or spray paint or airbrush. Again, if spraying, several thin coats are better than one thick coat. If you are going to decal the model after painting, use a glossy paint or coat the flat paint with a gloss coat before decaling. Dry transfer decals do not require a gloss coat.

Apply the decals by wetting them, then sliding them onto the model near where it will be placed and float it into the final position on a drop of water. When it is in place touch a corner of a paper towel to the edge, wicking out the pool of water. Coat the decal with Walther's Solvaset or Microscale's Micro-Set, to soften the decal and help it snuggle down onto the surface. A final flat finish will not only make the model more realistic, it will protect the decals from being chipped or rubbed raw by handling, and any weathering you do won't build up around the edges of the decal.

From here, simply add your couplers and trucks to the model, weather it to your taste and put it on the layout! You'll be more proud of every model you turn out that you put your time and effort into, and your friends and visitors will be impressed that you have something unique running on your layout that can't simply be bought off the shelf and placed on the rails. A resin car kit will provide hours of enjoyment in the building and detailing, and dollar for dollar may be one of the best entertainment investments you can make in the hobby.

Amesville Shops was founded to serve the needs of early-period modelers (1875 to 1910) who need good, accurate and prototypical cars for their layouts.

Counter Gadget – A Switching Timer/Move Counter

Fred Miller, MMR

Ever since John Allen introduced his “Time Saver” switching layout, model railroaders have been interested in the car switching challenge offered by a small layout. Some modelers have incorporated the equivalent of the “Time Saver” track configuration into their layouts. The switching layout has also become popular as a challenge for kids, old and young, at train shows.

In general the switching challenge consists of a series of freight cars placed at various spur locations and the “contestant” must move those cars to other specified locations. When such a “challenge” is offered, the measurement of a trainman’s success is in accomplishing the switching orders in a minimum of moves, and sometimes in the least amount of time.

When working with a small layout at a train show, no means of easily capturing the move counts or elapsed time has been available. This article describes the construction of an electronic gadget which can count both the train moves and the elapsed time so either moves, or time, or both can be the measurement of success. This electronic circuit detects and counts the change in polarity of the train propulsion DC power. (A change in direction is equated to a “move.”) The circuit also keeps track of the elapsed minutes from the beginning of a switching challenge.

How the Counter Gadget works

The heart of the Counter Gadget is the PICAXE micro-controller chip. It is programmed to recognize the signals from the Rail Voltage detectors to increment the “moves” count. The + voltage and – voltage are decoded with a LM339 comparator chip and fed to the micro-controller. The micro-controller chip also maintains an elapsed timer which increments on the display in tenths of a minute (6 seconds). As appropriate, the moves count and time count are sent to three-digit seven-segment LED displays through a display driver chip. The Moves Count will increment at each change in track voltage polarity, counting up to 999 and then recycling from 001. It is assumed that a change in train direction indicates another move. Stopping and then continuing in the same direction is not counted as a move. Similarly, the Timer Count increments in tenths of a minute up to 99.9 minutes and then recycle over again from 00.0.

Although the Counter Gadget is ideally powered by a 9 VDC “wall wart” power supply, a supply of 6VDC through 12VDC could safely be used. The Counter Gadget is also connected to the DC rails or DC train control output. If connected to the rails, it should be at a location that remains powered and not disabled by turnouts, etc. Note that the Counter Gadget is designed to

work with DC powered trains, NOT DCC.

The STOP/RUN toggle switch is used to begin a new Switching Challenge (RUN position) with a moves count of 000 and a time count of 00.0. Flipping the toggle switch to the STOP position will cause the unit to cease counting of both moves and time, but continue to display the last achieved counts for bragging rights, etc. The toggle switch must be reset to RUN to zero out the counts and begin incrementing for a new switching challenge.

Construction

The circuit can be built and attractively housed for approximately \$50 dollars in parts. Most parts are readily available from electronic parts suppliers such as Digikey, Mouser or Jameco. A parts list with Jameco item numbers and prices is included later in the References section. A small micro-controller is at the heart of the counter circuit. The micro-controller logic is programmed in PICAXE Basic language, a very easily understood and downloadable facility made available free from Revolution Education, a UK educational organization. See notes in the References section for availability of the BASIC software for the micro-controller, or alternatively, a pre-programmed chip.

The author’s version of the Counter Gadget was constructed using standard IC sockets mounted on perf board. The board was cut to a size which would fit in the project box. A cardboard template was used to check the fit. The sockets for the 7-Segment LED displays were kitbashed from a larger 24 pin socket since 12 pin sockets in the configuration needed are not readily available. After locating the 7-Segment displays in their sockets the “project box” lid was cut to allow the displays to be visible. An exact cut is not necessary since a covering plate can be made out of black styrene with more precise dimensions. Again a cardboard template was used to ensure proper locations when cutting the “project box” cover and the black styrene. A transparent red plastic sheet mounted between this covering plate and the project box lid nicely hides the LED displays, except for the lit up number segments. PC software was used to make the various labels. These were printed on standard full sheet label stock, e.g. Avery #5265.

Following a “wiring aid” multi-color drawing, each circuit connection was soldered on the back of the perf board using a lower watt soldering iron with a sharp point. A visual check of each wire to the circuit diagram

Continued on page 14



The Philadelphia Chapter Pennsylvania Railroad Technical & Historical Society

Preserving the history of the Pennsylvania Railroad

Modelers Forum & Presentations at all scheduled chapter meetings

Member publications: "High Line" and "Keystone Chronicles" magazines.

Membership actively modeling, collecting and preserving PRR equipment & images.

BE OUR GUEST AT A FUTURE CHAPTER MEETING OR EVENT

Subscribe to the Philadelphia Chapter newsletter

Membership information/application available on-line



 www.philaprrths.com

 www.facebook.com/philaprrths

Support Your NMRA Region and Purchase These Great Products from MER



MER Lapel Pin/Tie Tack



MER Cloth Patch

Only available to MER members.
Your NMRA or MER member number.

MER Cloth Patch

MER Lapel Pin/Tie Tack

The Locals, all issues 1947 - 2012 on CD

Make checks payable to: Mid-Eastern Region

\$3.00 ea. includes S&H \$ _____

\$6.00 ea. includes S&H \$ _____

\$5.00 ea. postpaid \$ _____

Donation \$ _____

Total Amount Enclosed \$ _____

Ship to:

NAME _____

ADDRESS 1 _____

ADDRESS 2 _____

CITY _____ STATE _____ ZIP _____

Mail to:

Roger Ossman

MER Merchandise Sales Agent

3307 Englewood Road

Wilmington, DE 19819-3323

New Membership Recruitment Program

As an aid to membership recruitment, NMRA instituted a six month "Rail Pass" trial membership program which costs the applicant \$9.95. Building on this idea, the MER is instituting a program whereby it will pay the \$9.95 Railpass fee for interested applicants in the MER. In other words, we are making available FREE six month Railpass trial memberships to encourage recruitment of regular members.

What's covered?

Same as Railpass—receive six issues of NMRA Magazine, three issues of The Local, eligibility to attend conventions and meets, eligibility to participate in contests.

What's not covered?

Same as Railpass—applicants cannot vote or hold office, and will not receive the New Member Pak from national (it's rather expensive).

Who can be recruited?

Anyone living within the MER who has not been a member of NMRA during the past two years or a prior Rail Pass member.

How will the recruitment process work?

(1) The prospective member fills out the MER trial membership application form which was sent to all division superintendents (not the standard NMRA Railpass form) (2) The "recruiter" should sign

the form, and then forward it to: Bob Price, Business Manager, 801S. Newton Lake Drive, Collingswood, NJ 08108. (3) Bob will record the information he needs in his data base, and will forward the application to the MER Treasurer. (4) The Treasurer will add the necessary check and forward the application and check to the national headquarters in Soddy Daisy.

What happens after the member's six month trial period?

The Railpass trial member will receive a standard dues notice from national headquarters. We hope a substantial number of Railpass trial members will sign up to become regular members.

Are there limits on the program?

The MER initially allocated \$2,000 for this program. When this funding is depleted Division Superintendents and members of the MER Board of Directors will be notified. At this time the program will be reevaluated by the MER Board of Directors. It has proven to be an excellent means to recruit new members. If successful, we will try to continue it.

For questions?

Contact Bob Price, Business Manager (mailing address is below, (856) 854-8585, MER-BusMgr@comcast.net), or P. J. Mattson, MER President (see contact information on page 2).

National Model Railroad Association (NMRA) Mid-Eastern Region Application for Free "Railpass" Trial Membership

YES, please sign me up for a free six month Railpass trial membership in the NMRA—which includes membership in the Mid-Eastern Region, and in my local Division. During this six month period, I understand that I may attend conventions and meets, and participate in contests. I will receive NMRA Magazine, the monthly national magazine, and The eLocal, the bi-monthly regional newsletter if an email address is provided. I will not be eligible to vote, hold office, or receive a New Member Pak.

I also understand that the \$9.95 cost of this six month Railpass trial membership is being paid by the Mid-Eastern Region. (Regardless of who pays, six month \$9.95 memberships are available only once to each person.)

At the end of the six months, I may join NMRA, paying the regular active member dues.

During the past two years, I have not been a member of NMRA, nor have I been a RailPass member.

Name: _____

Street Address: _____

City/State/Zip: _____

Phone: (____) _____

Email: _____

Scale(s): _____

Signature of Sponsor: _____ (Required)

Title of Sponsor: _____ (Required)

(A Regional or Divisional officer or board member)

When this form is completed
mail it to:

Bob Price
MER Business Manager
801 S. Newton Lake Drive
Collingswood, NJ 08108

Do not mail it directly to
NMRA headquarters in Soddy
Daisy, TN.

June 2015

or wiring aid is a good step at this time. The author marks off each circuit connection on a printout of the circuit to double-check the route. This marked up printout also serves well to determine if all wires have been completed. A continuity check with a meter or other device between points on the IC sockets is also a suggested check. Before plugging in the IC chips and displays, the unit should be further tested by applying power and checking for +5VDC and 0VDC (ground) at, and only at, appropriate IC socket points using the wiring diagram. When all these tests check out, the ICs and 7-segment LEDs can be plugged in and the circuit powered up again. After every 6 seconds, the Minutes count should increment by one-tenth of a minute. When a DC Voltage of at least 1 volt is applied to the Rail input leads, and then reversed, the Moves count should increment.

When the operation of the circuit was confirmed, the author applied 5-minute epoxy over the various soldering points to ensure no damage or shorts to the wiring would occur from subsequent handling.

Two scrap styrene strips were added inside the "Project Box" to keep the "perf-board" at the correct level. A good alignment is for the seven-segment displays to be

just below the top of the lid. Holes were drilled on the two ends for the RUN/STOP toggle, a Power socket and the track connection leads. The screw base on the Power Socket was not deep enough to use the standard nuts, so the unit was ACC'd into place.

As can be seen in the various Figures, the wiring of the circuit components might be somewhat of a challenge to some model railroaders not comfortable with electronic wiring circuitry. If enough interest is generated, the author would develop a printed circuit board to simplify the construction. In addition, a pre-programmed micro-controller chip could be made available based on interest.

The PICAXE software listing is available from the author (tractionfan @ aol.com) at no charge by an email attachment. If enough interest is generated, the author would develop a printed circuit board to simplify the construction. In addition, a pre-programmed micro-controller chip could be made available.

Note from the Editor

Images associated with this article are too small to print clearly so they have been appended in full size to the electronic version.

The MER Wants You

With 2016 being an even number year, it is time to nominate and elect the four Officer positions for the MER Board; President, Vice-President, Secretary, and Treasurer. Those elected will serve two (2) terms working with the three directors in running the operations of the Region's activities. Any current member of the Region in good standing can self-nominate him/herself for any of these 3 positions - Vice-President, Secretary, and Treasurer. A candidate for President requires prior MER Board membership or having served in a Superintendent position. All that is required is a 200 word candidate statement stating your qualifications and goals/desires for serving (a separate 500 word version can be used for the MER web site). Also, a passport size photo of you must accompany your statement. Both of these items must be received by any member of the nominating committee before APRIL 15th, 2016 (TAX DAY). Either email or snail mail is acceptable. If you miss the date (4/15), then you must also include a partition signed by 25 current members supporting/endorsing your nomination. The April deadline is the best way to go. Members of the nominating committee are:

Bob Minnis — kahlualab@aol.com
Bruce Barrett - geenjeeps2@yahoo.com

John Janosko — johnajan@ernbarqmail.com

Ballots will be mailed to all Region members in the late July — August 1 time frame. Ballots must be returned by early September; the exact date will be printed on the ballot. The winning candidates will assume their duties at the conclusion of the annual membership meeting at the end of the 2016 convention. If you enjoy this hobby of model railroading, please give some serious consideration to supporting the Region by volunteering. Successful service as an elected official counts toward the AP certificate of "Association Official".

FOR SALE

HO kit "Point of Rocks"

Victorian brick B&O Sstation by Model Tech Studios Showcase Series. Kit #233 of 250 (beautiful well detailed kit sold out in ~2001) in original box. \$1200 including shipping.

Contact:
John Carrico, Mer 1035
After 2PM Home Tel# 973 827-1480

CALLBOARD

Coming Events

South Mountain Division Mini Con

April 16, 2015, from 9 AM to 4 PM

Blue Ridge Fire Hall

13063 Monterey Ln.

Blue Ridge Summit, PA

South Mountain Division and Mainline Hobby Supply host the 4th annual Mini Con. Come enjoy this one day free event one block north of Main Line Hobby Supply, consisting of prototype and modeling presentations, formal and informal clinics, modular displays, and interaction with your fellow hobbyists and beginners. This no admission charge, education event is open to the public for the promotion of the hobby of Model Railroading.

Contact: Don Florwick

DJFlorwick@comcast.net

717-414-0660

<http://www.smdnmra.org/> for updates

Carolina Southern Division

Railroad Model University

January 23, 2016

Christ the King (CTK)

13501 S. Tryon Street

Charlotte NC, 28278

In January of each year the Carolina Southern Division 12 hosts a Railroad Model University aimed at the new comer. The idea is to share our love of model trains with those who are excited with memories of Christmas past or new gifts of trains in the present. We learned that giving help to others has big rewards to us.

More information at:

<http://www.carolinasouthern.org/>

James River Division Meets

January 9, 2016 – Fredericksburg, Virginia

Location: To Be Announced

9:00 AM to 1:15 PM

Clinic: Timetable & Train Order – Steve King - This clinic will be the entire session.

Modeling Theme: Any structure providing train orders and associated TT&TO messages.

Layouts – one or two, details at the meet.

March 12, 2016 -- Richmond, Virginia.

Location: To Be Announced

Doors open at 9:00 AM and we start at 9:30 AM

Clinics:

Modeling Chain Link Fences – John Winters

Recycled Freight Cars - Jack Brown

Modeling Theme: Passenger Cars....more info to come.

Details and updates at

<http://jrdsnra.blogspot.com/p/meetings.html>

Delmarva Model Railroad Club Annual Open House

103 East State Street

Camelot Hall, 2nd floor

Delmar DE 19940.

Next to St. Stevens United Methodist Church

Great fun for the whole family! Come see over 8,000 sq.ft. of operating train layouts. Z Scale, N Scale N Trak Modules, HO layout, S Gauge, O Gauge Tinplate, O Scale Lionel, and LGB (G gauge).

Saturday, Jan 2nd from 11am - 4pm

Sunday, Jan 3rd from 12pm - 4pm

Saturday, Jan 9th from 11am - 4pm

Sunday, Jan 10th from 12pm - 4pm

More information at:

www.delmarvamodelrailroadclub.org or

302-856-9250 or 410-543-8077

Carolina Coastal Railroaders

Twenty First Annual Train Show

February 20 & 21, 2016

New Bern Riverfront Convention Center

203 South Front Street

New Bern, NC 28560

Ages 12 and up \$7.00, under 12 free with adult. Ticket is good for both days. Ten operating layouts, including Thomas the Tank Engine and Friends in HO & G Scale, over 25 vendors to sell and buy your old equipment, food concession, hourly door prize drawings.

<http://www.carolinacoastalrailroaders.org/2016.asP>

Contact: Joseph T. Hofmann

southernrrtrains@yahoo.com

(252) 474-4153

Achievement Program

Charles Flichman, MMR

Since the last report in The Local, the following Achievement Program certificates were earned and awarded:

Division 13 - Carolina Piedmont

William J. Hanley - Model Railroad Author

The Mid-Eastern Region, Inc., NMRA
An IRS Tax Exempt Organization
Business Manager
801 S. Newton Lake Drive
Collingswood, NJ 08108

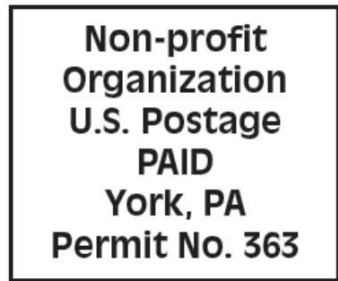

RETURN SERVICE REQUESTED

In This Issue

Boy Scouts and the MER	1
MER Staff and Contacts	2
From the Business Car	3
Keeping in Touch	3
Photographing Layouts	4
Delaware Valley Contest Results	6
Delaware Valley Turn Wrap Up	7
How to Build a Resin Kit	8
Counter Gadget - A Switching Move	
Counter and Timer	11
MER Recruitment Program	13
Achievement Program	14
Callboard	15

Subscriptions to **The Local**

Send Requests to MER Business Manager at above address

I want to receive the printed black& white version of The Local at \$9.00 per year (6 issues) \$ _____

I want to receive the free electronic **color** version of **The Local**

Email: _____

Donation \$ _____

Total Enclosed \$ _____

Name _____

Address _____

City _____ State _____

Zip (+4) _____

Email _____

NMRA # _____ Expire Date _____

Scale(s) _____ Telephone # _____

Make Checks payable to the "Mid-Eastern Region"

The Local welcomes articles, photographs and model railroad related material as contributions to members' mutual enjoyment of the hobby. Materials should have a wide appeal. The editor will exercise all due care of submissions, but contributors should not send originals without having back-up copies of both articles and photographs. Editors, by definition, reserve the right - and have the responsibility - to make corrections, deletions, and changes to accommodate space. Upon receiving any submission, the editor will confirm receipt, and, at a later date, indicate the anticipated edition the submission will appear in The Local. If you do not receive a postcard or email within two weeks, please resend your submission or contact the editor by phone.

Publication Schedule	Deadline
Jan/Feb	Dec 1st of previous year
Mar/Apr	Feb 1st
May/Jun	Apr 1st
Jul/Aug	Jun 1st
Sept/Oct	Aug 1st
Nov/Dec	Oct 1st

If you are interested in advertising with the Mid-Eastern Region of the National Model Railroad Association, please contact the editor. The current advertising rates (6 issues) for The Local are as follows, and must include camera ready are (jpeg, pdf, bmp, tiff formats):

Callboard ads (30 - 50 words, Div and Clubs Only).....	Free
Business Card size	\$60.00
Quarter Page ad	\$125.00
Half Page ad.....	\$225.00
Half Page ad per issue (Div only).....	\$25.00

Files for the Switching Move Counter/Timer

I can't believe that anyone reading this would be unfamiliar with John Allen's Timesaver layout, but just in case, here it is.

JOHN ALLEN'S TIMESAVER TRACK LAYOUT & STORAGE CAPACITY

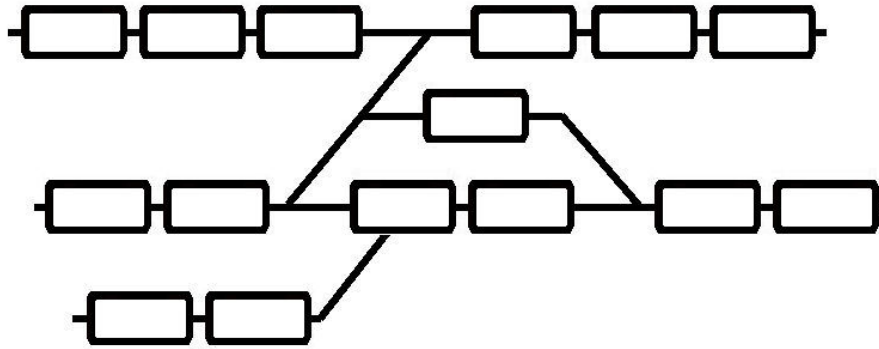

MOVE/TIME COUNTER CIRCUIT FUNCTIONS

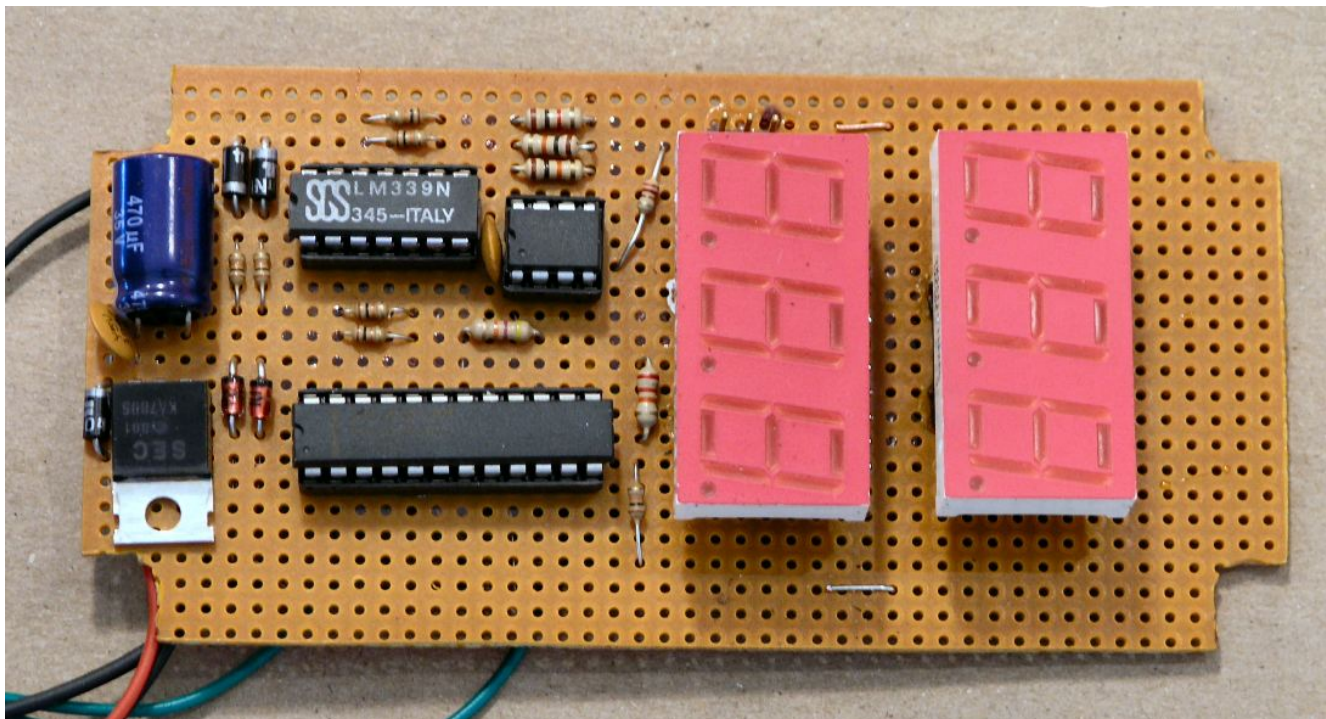
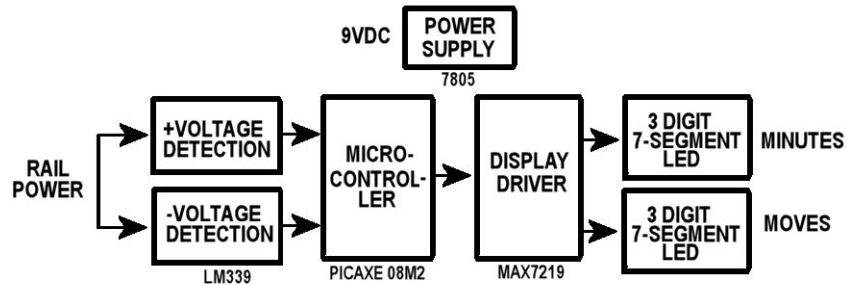

COUNTER GADGET - MOVES & MINUTES COUNTER

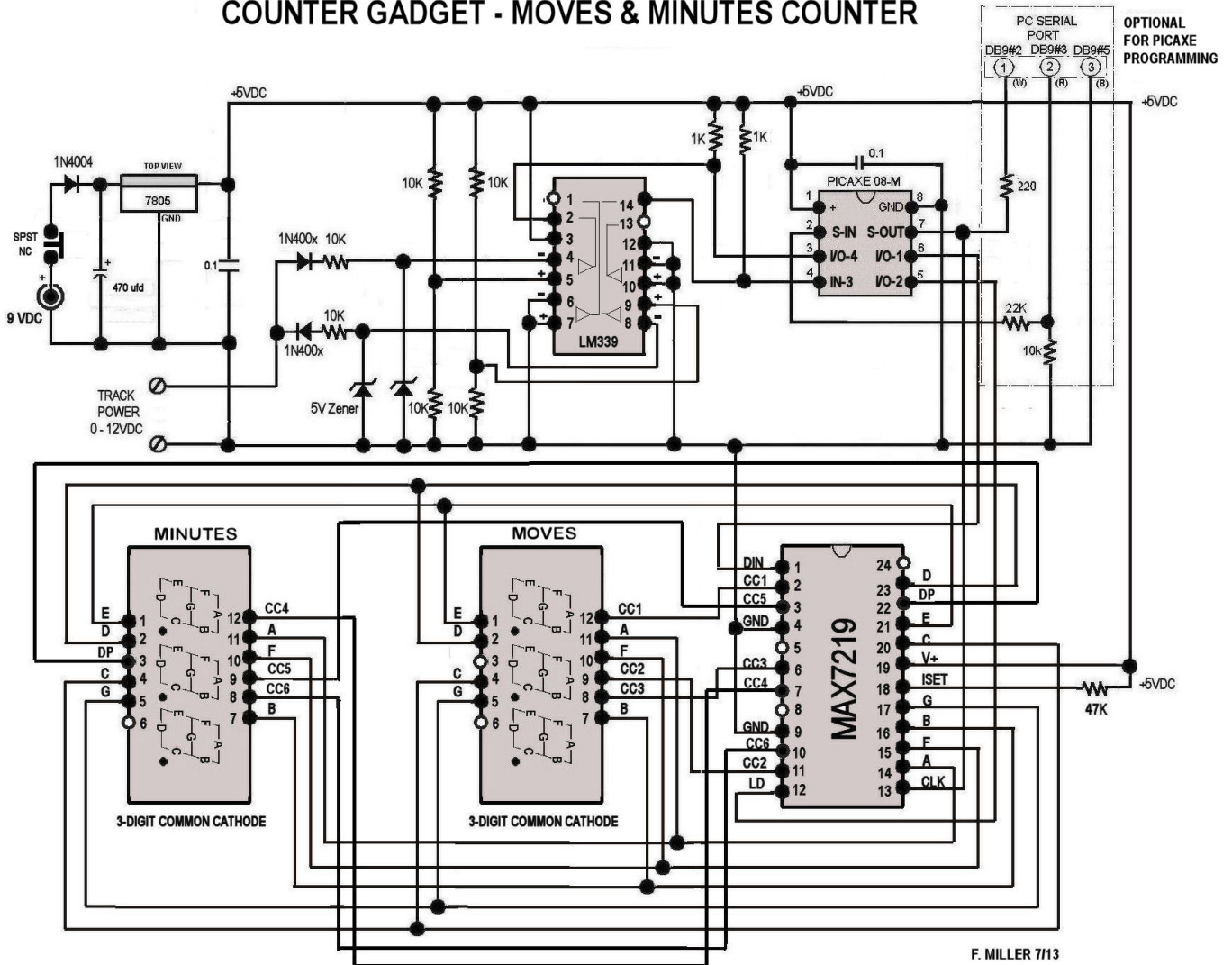

This is the schematic for the counter/timer. The microcontroller that runs it is the little 8 pin IC in the upper right. Note that it can be reprogrammed without removing it from the board.

The wiring doesn't have to be pretty to work. The IC socket leads are just bent over, a wire soldered to them, and some insulating resin (epoxy, RTV silicone, etc.) applied to prevent short circuits.

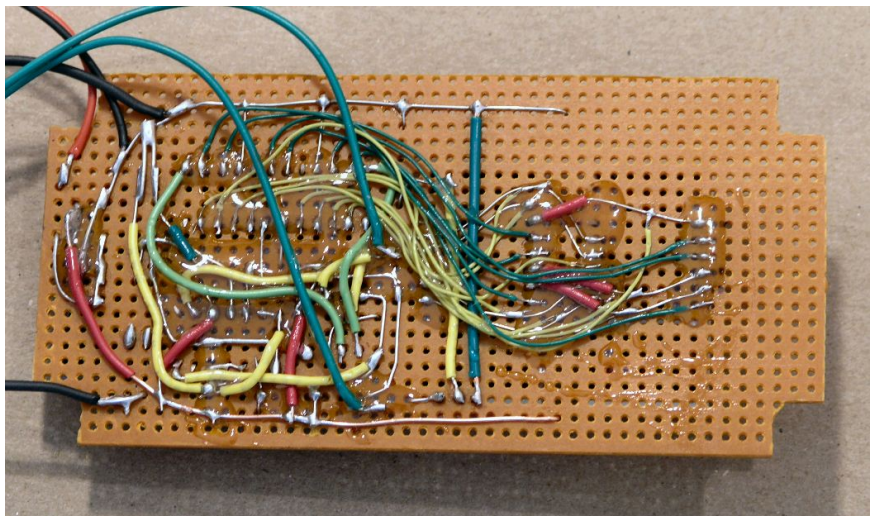
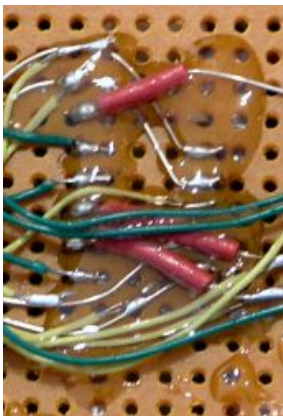

COUNTER GADGET - MOVES & MINUTES COUNTER

VERSION 2 (WITH RUN/STOP TOGGLE) 7/22/13

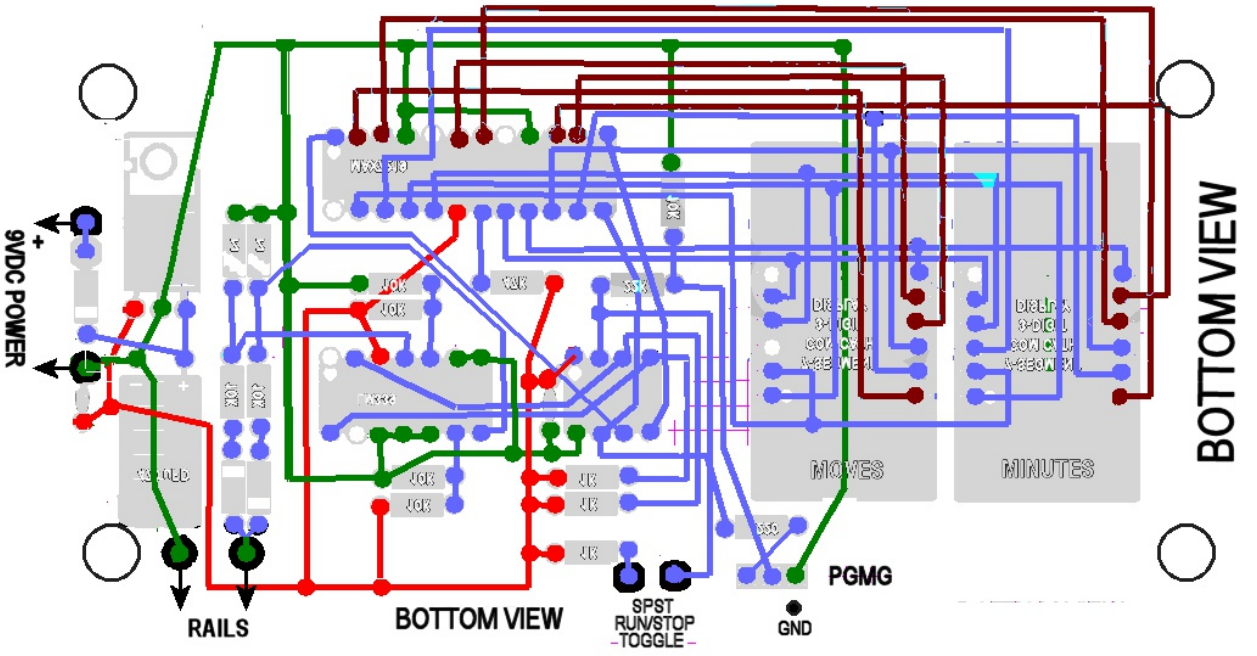
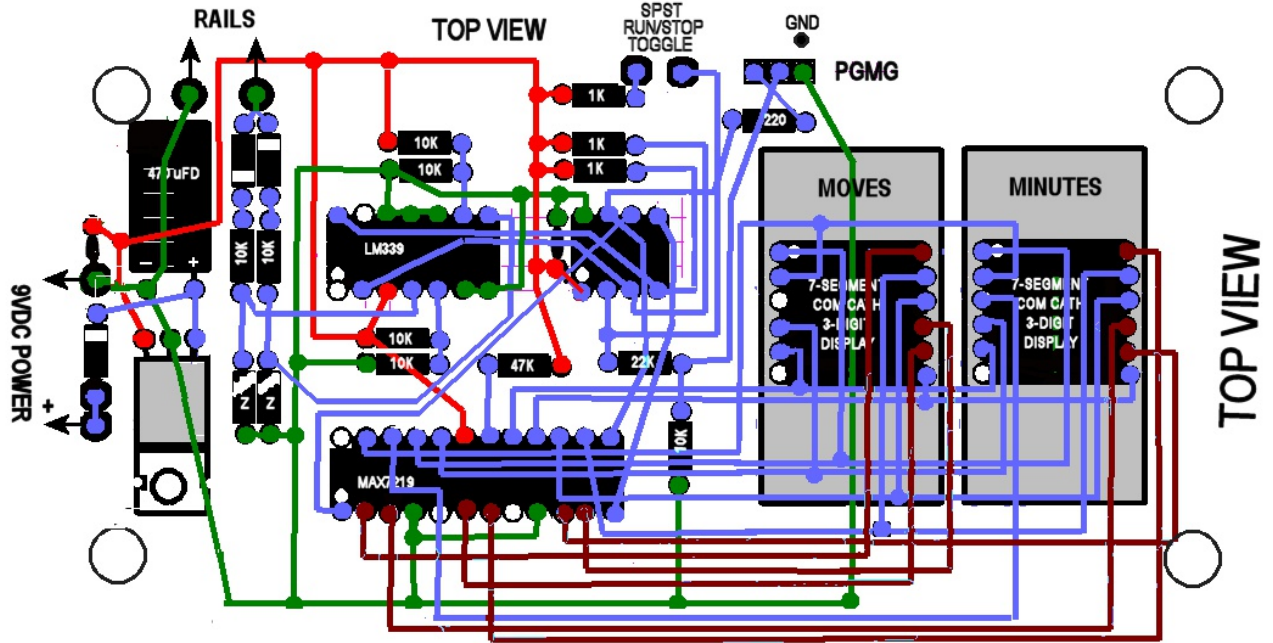

PARTS LIST FOR COUNTER GADGET

QTY	DESCRIPTION	JAMECO PART NO.	JAMECO PRICE	TOTAL PRICE	
2	7-SEGMENT 3 DIGIT COMMON CATHODE DISPLAY	308224	\$ 2.49	\$ 4.98	
1	MAX7219 DISPLAY DRIVER	312160	\$ 7.95	\$ 7.95	
1	LM339N QUAD COMPARATOR	23851	\$ 0.25	\$ 0.25	
1	24 PIN IC SOCKET	683163	\$ 0.26	\$ 0.26	
1	14 PIN IC SOCKET	683112	\$ 0.13	\$ 0.13	
1	8 PIN IC SOCKET	526299	\$ 0.12	\$ 0.12	
1	28-PIN SOCKET (TO BE KITBASHED INTO TWO)	40328	\$ 1.19	\$ 1.19	
2	1N47331 5.1V ZENER DIODE	36097	\$ 0.06	\$ 0.12	
1	7805 TO-220 5V 1A VOLTAGE REGULATOR	51262	\$ 0.29	\$ 0.29	
3	1N4004 DIODE @ 5¢	35991	\$ 0.05	\$ 0.15	(1)
7	10K 1/4W RESISTOR @4¢	691104	\$ 0.04	\$ 0.28	(1)
2	1K 1/4W RESISTOR @4¢	690865	\$ 0.04	\$ 0.08	(1)
1	47K 1/4W RESISTOR @ 4¢	691260	\$ 0.04	\$ 0.04	(1)
1	470 UFD CAPACITOR 25V	31183	\$ 0.35	\$ 0.35	
2	0.1 CERAMIC DISK CAPACITOR @13¢	151116	\$ 0.13	\$ 0.26	(1)
1	SPST TOGGLE SWITCH	317287	\$ 0.75	\$ 0.75	
1	DC POWER JACK 2.5MM	202388	\$ 1.19	\$ 1.19	
1	WALL TRANSFORMER 9VDC 500MA	1953647	\$ 10.95	\$ 10.95	
1	PERF BOARD (SOLD IN 2.38 x 4 IN)	616690	\$ 5.95	\$ 5.95	(3)
1	22K 1/4W RESISTOR (OPTIONAL FOR PGMG)	691180	\$ 0.04	\$ 0.04	(1)
1	220 OHM 1/4W RESISTOR (OPTIONAL FOR PGMG)	690700	\$ 0.04	\$ 0.04	(1)
1	3-PIN MALE HEADER (OPTIONAL FOR PGMG)	421489	\$ 0.35	\$ 0.35	
1	PICAXE 08M2 (AVAILABLE FROM SPARKFUN)	-	\$ 2.95	\$ 2.95	(2)
2	ALLIGATOR CLIP (EG RADIO SHACK 270-374)	-	\$ 0.35	\$ 0.70	(1)
1	PROJECT CASE	18914	\$ 3.95	\$ 3.95	
-	HOOK UP WIRE, STYRENE FACE PLATE, RED PLASTIC	-	-	-	
				\$ 43.32	

NOTES: (1) SOLD IN MIN QUANTITIES. SMALL QTY AT RADIO SHACK BUT GREATER UNIT COSTS

(2) PICAXE 08M2 SOLD AT SPARKFUN OR PHANDERSON BUT NEEDS PROGRAMMING

(3) LARGER, (WHEN AVAILABLE), AT RADIO SHACK, EG 276-1394 (4.5"X6"@\$3.49)

REFERENCES FOR COUNTER GADGET PROJECT

REQUESTS FOR LARGER PRINTS & LISTINGS	tractionfan@aol.com (AUTHOR)
FURTHER INFO ABOUT PROJECT	
INFO ABOUT PROGRAMMED PICAXE CHIPS	
INFO ABOUT PICAXE MICRO-CONTROLLERS	http://www.picaxe.com/
MAIL ORDER PARTS (JAMECO)	www.jameco.com
MAIL ORDER PARTS (RADIO SHACK)	www.radioshack.com
MAIL ORDER (BLANK) PICAXE 08M2	www.sparkfun.com , www.phanderson.com
INFO ABOUT RRSWITCH (PC GAME)	www.fnbcreations.net/challengeproducts